

## SELEC



(96 x 96)

### Ordering Information

Model	Supply Voltage
EM306	90 to 270 VAC/DC

### Terminal Connections

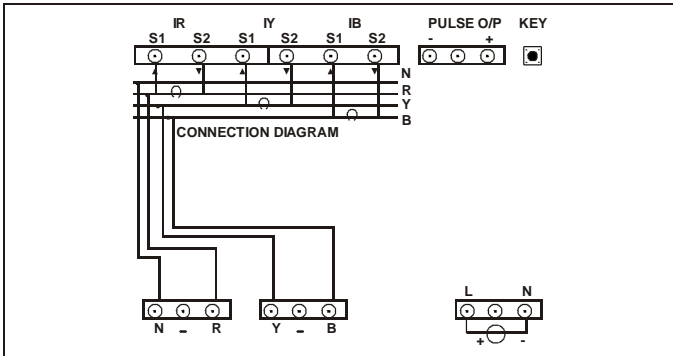

### Dimensions (in mm)

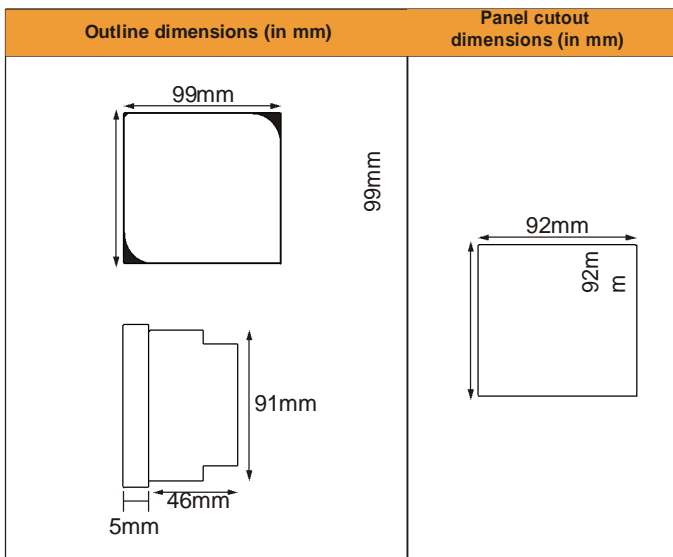

### Technical Specifications

<b>Display</b>	6 digit 7 segment LED display. Height 0.5"
<b>Led Indications</b>	<b>INT</b> - Integration of energy <b>X10</b> - Resolution is 10 <b>REV</b> - Reverse connected CT warning
<b>Input</b>	3 Ø - 4 wire and 1 Ø - 2 wire input type
<b>Rated Input Voltage</b>	Nominal 300 VAC max. 3-phases (R,Y,B) with respect to Neutral.
<b>Frequency Range</b>	50 Hz
<b>Rated Input Current</b>	Nominal 6A maximum
<b>Ct Primary</b> (selectable via rear key)	5, 30, 40, 50, 60, 75, 80, 100, 150, 200, 250, 300, 400, 500, 600, 800, 1000, 1200, 1500, 1600, 2000, 2500, 3000, 4000, 5000.
<b>Burden</b>	0.5 VA@5A per phase
<b>Measurement</b>	kWh (not resettable)
<b>Accuracy</b>	Class 1
<b>Auxiliary Supply Range</b>	90 to 270 VAC / DC, 50/60 Hz
<b>Output</b>	<b>Pulse Output:</b> Voltage range - 24 VDC Current capacity - 100 mA max <b>Pulse Width:</b> 500 ms ± 50 ms.
<b>Temperature</b>	<b>Operating:</b> 0 to 50 °C <b>Storage:</b> -20 to 75 °C
<b>Humidity</b>	85% non-condensing
<b>Mounting</b>	Panel mounting
<b>Weight</b>	225 gms

### Also Selec Make Economical PLC and HMI



For **Quote and Solutions** mail us at [selectautomation@airtelmail.in](mailto:selectautomation@airtelmail.in)

Visit **Us** at [www.selectautomation.net](http://www.selectautomation.net)