

OPERATING INSTRUCTIONS

RC2108



Please maintain these instructions and review them prior to using the unit:

⚠Warning:

1. This unit is panel mounted type with its output terminals getting connected to the host equipment. Such equipment shall also comply with basic EMI/EMC and safety requirements like BSEN 61326-1 and BSEN 61010 respectively.
2. To avoid electric shock, power supply of the unit should be kept off while wiring. Wiring should be done strictly as per the terminal layout, given in the manual.
3. Use lugged terminals to meet M3 screws.
4. The unit does not have a built-in fuse. External fuse with a rating of 275VAC/1A is recommended.

⚠Caution:

1. This unit is not intended for outdoor use.
2. The power connection cable must have a cross-section of at least 1mm² and insulation capacity of at least 1.5kV.
3. The output connections must not be loaded beyond the specified values/range.
4. Avoid inflow of dust and contact of conductive material with the internal circuitry of the unit.
5. The unit must not operate in presence of heating sources, caustic vapors, oil, steam, vibration or impact etc.
6. Clean the equipment with a clean soft cloth, do not use any organic cleaning agent. Care must be taken to avoid entry of water into the circuitry through the ventilation holes.

Specifications:

DISPLAY

4 digits, 0.5" height, red 7 segment LED.

SUPPLY VOLTAGE

90 to 270 V AC/DC.

RATE MODE

RPS, RPM, RPH (programmable).

RANGE

4 to 9999 RPM.

INPUTS

3-30 VDC from Proximity switches (PNP), Encoders, Potential free contacts, Limit switches etc..

SETPOINTS

2 (Low alarm and High alarm).

SCALE FACTOR

Programmable from 0.001 to 9.999 x 10ⁿ
n = 0, 1, 2, -3, -2, -1.

MAXIMUM INPUT SPEED

3.5kHz.

LED INDICATION

Low alarm status,
High alarm status.

ACCURACY

±0.05 %.

SENSOR SUPPLY

12 VDC(±10%) , 30 mA. Short circuit protected.

CONFIGURATION LOCK

via rear terminals.

OUTPUT

1 C/O each for high and low alarm.

HOUSING

Flame retardant plastic.

OPERATING TEMP.

Operating: 0 to 50°C.
Storage: -20 to 75°C.

HUMIDITY

95% RH

WEIGHT

approx 200 gms

Overall Dimensions:

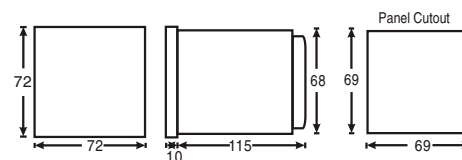

Terminal Connections:

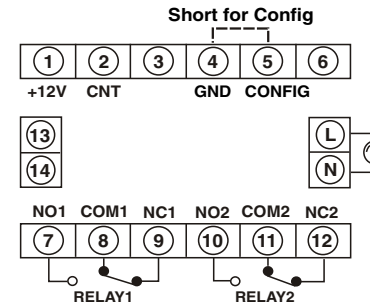

Terminal	Description
1	+12VDC sensor supply
2	Count input
4	GND
4 - 5	Short to enter configuration
7 - 8 - 9	NO - COM - NC of relay1- low alarm
10 - 11 - 12	NO - COM - NC of relay2- high alarm
L - N	Live - Neutral.

Input connection for proximity sensor:

With PNP sensor:

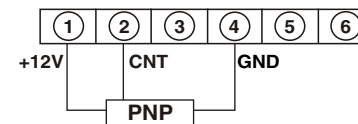

With NPN sensor:

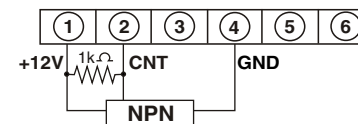

Note: Sensor color codes-
Red --> +12V, Green --> CNT, Black --> GND
Brown --> +12V, Black --> CNT, Blue --> GND

Setting numerical values:

** indicates blinking digit. The blinking digit, increments by 1 for every press of the ▲ key and rolls over from 9 to 0. The blinking shifts to the next digit (right) for every press of ► key. Using these keys user can set the required value.

CONFIGURATION SCHEME (parameter setting)

To enter configuration scheme:

- 1) Short terminal no 4 & 5
- 2) Turn power ON.
- 3) Program configuration setting as per instructions below:

1. To select scale factor mantissa

Default : 1.000

Key press	Display	Description
Scale factor mantissa	1.000*	Set between 0.001 to 9.999 as described above.

2. Press ► key to select scale factor exponent

Default : 0

Scale factor exponent	2 0*	10 ⁰ = 1
Press ▲	2 1*	10 ¹ = 10
Press ▲	2 2*	10 ² = 100
Press ▲	2 .3*	10 ⁻³ = 0.001
Press ▲	2 .2*	10 ⁻² = 0.01
Press ▲	2 .1*	10 ⁻¹ = 0.1

NOTE: dp indicates -ve sign.

3. Press ► key to select Power ON delay

Default : 000

Power ON Delay	000*	000 to 999 sec
----------------	------	----------------

Power ON delay: If alarm condition is present at power ON, the alarm output will be activated only after the time set as, Power ON delay.

Key press	Display	Description
4. Press \blacksquare key to select Alarm delay Default : 000		
Alarm Delay	$\cdot 000$ *	000 to 999 sec
dp indicates Alarm delay. Power ON delay: When alarm condition occurs, the alarm output will be activated only after the time set as alarm delay. Note: At Power ON, the higher of the two delay values is considered.		
5. Press \blacksquare key to select Hysteresis Default : 05		
Hysteresis	5 05*	00 to 99 least counts.
Low Alarm is activated when Rate \leq LA value. It turns off when, Rate $>$ (LA value + Hysteresis). High Alarm is activated when Rate \geq HA value. It turns off when, Rate $<$ (HA value - Hysteresis).		
6. Press \blacksquare key to select Resolution Default : 1		
Resolution	\square *	
Press \blacktriangle	0.1*	
Press \blacktriangle	0.01*	
Press \blacktriangle	0.001*	
7. Press \blacksquare key to select Mode Default : 1 (RPM)		
Mode	1*	RPM
Press \blacktriangle	2*	RPH
Press \blacktriangle	0*	RPS

8. Press \blacksquare key to select Reset all

Reset all \square 0* No Action

Press \blacksquare key to complete configuration.

Press \blacktriangle \square 1* No Action

Press \blacktriangle \square 2* No Action

Press \blacktriangle \square 3* No Action

Press \blacktriangle \square 4* No Action

Press \blacktriangle \square 5* No Action

By pressing \blacksquare key now, all parameters will reset to factory settings and display will go to step 1 (scale factor mantissa setting).

Press \blacksquare \square 1000* All parameter values set to factory setting

To quit configuration:

- 1) Turn power off
- 2) Remove link between terminal no 4 & 5
- 3) Turn power on

 If terminal no 4 & 5 are shorted at power on, rate indicator will go in to the configuration mode. To quit configuration setting mode, turn power off, remove link between 4 & 5 & switch power on.

Note:

1. If input speed is above the indication range, display indicates 1 in the MSD position.
2. If input speed is below the indication range, display indicates 0.

TO SET ALARMS

Press \blacktriangleright for 3sec to set Low Alarm value
Default : 0000

\square 0000* Low Alarm value

The blinking digit increments by 1 for every press of the \blacktriangle key & rolls over from 9 to 0. The blinking shifts to next digit (right) for every press of \blacktriangleright key. Using these keys user can set the required value. Press \blacksquare key to enter the Low Alarm value & come out of programming for Low Alarm.

Press \blacktriangle for 3sec to set High Alarm value
Default : 9999

\square 9999* High Alarm value

The blinking digit increments by 1 for every press of the \blacktriangle key & rolls over from 9 to 0.

The blinking shifts to next digit (right) for every press of \blacktriangleright key. Using these keys user can set the required value.

Press \blacksquare key to enter the Low Alarm value & come out of programming for Low Alarm.

NOTE: High Alarm value should always be greater than the Low Alarm value. If high alarm value is set lower than the low alarm value or vice versa, the unit will not come out of alarm programming, till the values are corrected.

TO READ ALARMS

Key press (MOMENTARY)	Display	Name / Description
Press \blacktriangleright	\square 0000	Low Alarm value
Press \blacktriangle	\square 9999	High Alarm value

NOTE: Maximum display time is 3 sec.

TYPICAL APPLICATION:

Objective: To display the delivery rate of the cord (meters / minute).

Data available:

Example 1:

Diameter of the measuring wheel = 10cm.
The proximity switch generates 1 pulse / rev. of the measuring wheel.

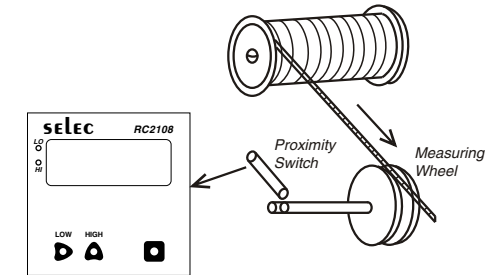

Calculations:

Circumference of the wheel = $3.142857 \times 0.1 = 0.3142857\text{m}$.
Therefore, the length of the rope delivered / revolution is 0.3142857m. Since the proximity switch gives 1 pulse / revolution, the display should increment by 0.3142857 for every pulse. Therefore, scale factor = 3.142857×10^{-1} .
Set scale factor mantissa = 3.14285
Exponent = 10^{-1}
The RC2106 will show rate in meters / minute.

Example 2:

In the same application, if 60 PPR encoder is fitted instead of proximity switch then:
a) The length of rope delivered per revolution is 0.3142857m.
b) The number of pulses / revolution = 60.
c) Length of rope delivered / count pulse = $0.3142857 / 60 = 0.005238\text{m}$.
The display should increment by 0.005238 for every pulse.
Therefore, scale factor = 5.23800×10^{-3} .
Set scale factor mantissa = 5.23800
Exponent = 10^{-3} for required display.

(Specifications subject to change as development is a continuous process).

Selec Controls Pvt. Ltd., India.

(Formerly Selectron Process Controls Pvt. Ltd.)
Tel:91-22-28476443/1882, Fax:91-22-28471733,
Website: www.selecindia.com
E- mail: sales@selecindia.com.