

# OPERATING INSTRUCTIONS

XC200NX / XC1200



Please maintain these instructions and review them prior to using the unit:

- Warning:**
- This unit is panel mounted type with its output terminals getting connected to the host equipment. Such equipment shall also comply with basic EMI/EMC and safety requirements like BSEN 61326-1 and BSEN 61010 respectively.
  - To avoid electric shock, power supply of the unit should be kept off while wiring. Wiring should be done strictly as per the terminal layout, given in the manual.
  - Use lugged terminals to meet M3 screws.
  - The unit does not have a built-in fuse. External fuse with a rating of 275VAC/1A is recommended.

- Caution:**
- This unit is not intended for outdoor use.
  - The power connection cable must have a cross-section of atleast 1mm<sup>2</sup> and insulation capacity of atleast 1.5kV.
  - The output connections must not be loaded beyond the specified values / range.
  - Avoid inflow of dust and contact of conductive material with the internal circuitry of the unit.
  - The unit must not operate in presence of heating sources, caustic vapors, oil, steam, vibration or impact etc.
  - Use clean soft cloth for cleaning. Care must be taken to avoid entry of water into the circuitry through the ventilation holes.

## SPECIFICATIONS :

### Display

6 digit, 7 segment LED display  
**XC200NX:** 0.3" height, **XC1200:** 0.5" height  
**Counter:** 6 digit display; **Rate:** 5 digit display

### Range

**Total:** Least count 0.0001, 0.001, 0.01, 0.1, 1  
**Rate:** Auto ranging 4.00 to 99999. RPM or RPH mode user selectable (minimum frequency for rate mode is 4.00 RPM)

### Set Points

Two set points, each programmable from 0.0001 to 99999

### Operating modes

- On delay
- Interval
- Time pulse repeat
- Auto reset

### Counting modes:

- Unidirectional (Up / Down)
- Quadrature
- Bi - directional

### Accuracy

Rate: 0.05 % ± 2 counts

### Count Inputs

a) Voltage pulse : 3 to 30V DC. Accepts Input from proximity switches, encoders, solid state devices, potential free contacts like limit switches, relays etc

### Maximum Input Frequency

30Hz, 2.5 kHz, 5kHz

### Sensor Supply

12VDC, 30mA (±10%)

### Scale Factor

Programmable from 0.00001 to 9.99999 x 10<sup>n</sup>  
 n = -5, -4, -3, -2, -1, 0, 1, 2

### Reset Input

- Front panel (user selectable)
- Remote reset  
 Minimum reset time for remote reset is 10msec.

### Relay Outputs

2 relays, 1C/O each rated 5 A @ 230 VAC / 24 VDC

### Memory Retention

10 years

### Configuration Lock

Via rear terminals to avoid inadvertent change in configured parameters

### Supply

90 to 270 VAC / DC, AC: 50 / 60Hz.

### Mounting

Panel mounting

### Housing

**CE marked products:** Flame retardant plastic  
**Non CE products:** ABS plastic.

### Temperature

Operating: 0 - 50°C, Storage: -20 - 75°C.

### Humidity

95% RH

### Weight

**XC200NX:** 375 gms  
**XC1200:** 260 gms

### OVERALL DIMENSIONS (All dimensions in mm)

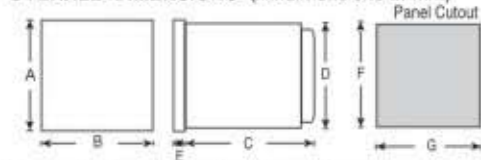

| MODEL   | A  | B    | C   | D  | E  | F  | G  |
|---------|----|------|-----|----|----|----|----|
| XC1200  | 50 | 97.5 | 88  | 45 | 10 | 46 | 92 |
| XC200NX | 72 | 72   | 115 | 68 | 10 | 69 | 69 |

## TERMINAL CONNECTIONS:

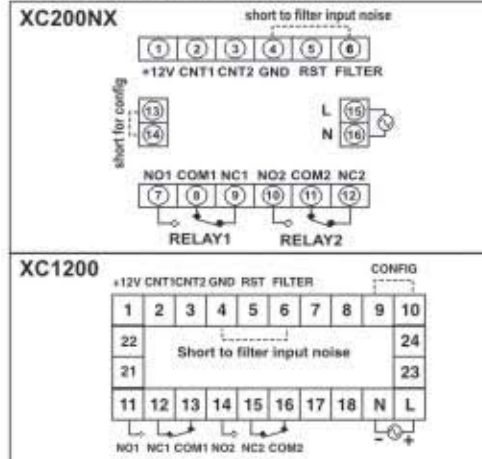

| Products     |              | Terminals                    |
|--------------|--------------|------------------------------|
| XC200NX      | XC1200       |                              |
| 1            | 1            | +12VDC (sensor supply)       |
| 2            | 2            | Count input 1                |
| 3            | 3            | Count input 2                |
| 4            | 4            | GND (-ve for sensor supply)  |
| 4 - 5        | 4 - 5        | Reset input                  |
| 4 - 6        | 4 - 6        | Short to filter input noise  |
| 7 - 8 - 9    | 11 - 13 - 12 | NO - COM - NC of relay1      |
| 10 - 11 - 12 | 14 - 16 - 15 | NO - COM - NC of relay2      |
| 13 - 14      | 9 - 10       | Short to enter configuration |
| 15 - 16      | L - N        | L (Live) - N (Neutral)       |

**NOTE :-** In some applications, proximity sensors pick up high frequency noise from nearby switching circuits like AC / DC drives. These get counted by the counter which then shows erroneous count / rate reading. By shorting terminals 4 and 6 as shown in fig above, these high frequency spurious pulses are filtered, by limiting input frequency to about 200Hz (1200 RPM).

### WIRING DIAGRAM FOR COUNT INPUT

(Sensor color codes:-  
 Red = +12V, Green = CNT, Black = GND  
 Brown = +12V, Black = CNT, Blue = GND)

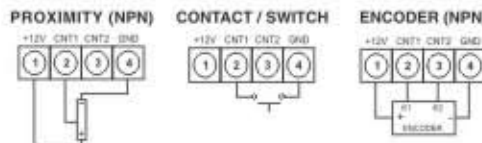

### Note:

- For PNP sensors, connect 1kohm resistor between CNT and GND terminals
- If the sensors (Proximity / Encoder) require more than 30mA current, use external power supply to power the sensors.

## RESETTING:

**By front key:** Press RST key continuously for 3 sec. The counter resets and starts counting again, and the display shows the rate or total as per selection.  
**Remote reset:** The unit can be reset from a remote pushbutton as per connections shown in the figure:

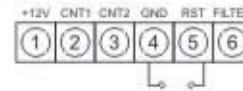

## TYPICAL CONNECTIONS FOR LOADS

1) For load current < than 0.5A

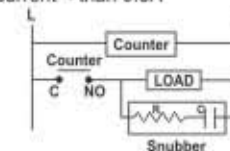

2) For higher loads use interposing relay/ contactor

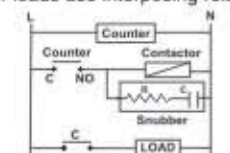

**NOTE:** Use snubber as shown above to increase relay life of counter.

## ELECTRICAL PRECAUTIONS DURING USE

Electrical noise generated by switching of inductive loads can create momentary disruption, erratic display, latch up, data loss or permanent damage to the instrument. To reduce noise:  
 a) Use of MOV / snubber circuits across inductive loads are recommended.  
 b) Use separate shielded wires for inputs, which are not bundled with mains power lines.  
 c) Use separate relay / contactor for actuating control / signal lines of counter.

### CONFIGURATION SCHEME (parameter setting)

- Before configuration: With power off, short terminal nos. 13 & 14 (for XC200NX) or terminals 9 & 10 (for XC1200)
- Turn power on
- Program settings as per instructions given below:

### 1. Scale factor mantissa

Factory setting: 1.00000

| Key Press             | Display          | Description                |
|-----------------------|------------------|----------------------------|
|                       | 5CL              | for 1 sec.                 |
|                       | * Blinking digit | Range: 0.00001 to 9.99999. |
| Scale factor mantissa | 1.00000          | Set as given below:        |

The blinking digit increments by 1 for every press of **▲** key and rolls over from 9 to 0. The blinking shifts to next digit (right) for every press of **▶** key. Using these keys the required value can be set.

**TO READ VALUES OF CONFIGURED PARAMETERS:**

| KEY PRESS (MOMENTARY) | DISPLAY                    | NAME / DESCRIPTION       |
|-----------------------|----------------------------|--------------------------|
| Press Δ [C-EOEL]      | #<br>000000                | Cumulative total         |
| Press Δ [b-EOEL]      | #<br>000000                | Batch total              |
| Press Δ [5CL]         | #<br>100000                | Scale factor mantissa    |
| Press Δ [EPN 0]       | Scale factor exponent      |                          |
| Press Δ [RESL]        | #<br>000000                | Resolution (least count) |
| Press Δ [UP]          | Counting mode              |                          |
| Press Δ [ZER0]        | Reset to zero              |                          |
| Press Δ [ON]          | Relay operating mode       |                          |
| Press Δ [NONE]        | Autoreset or TPR mode      |                          |
| Press Δ [FEE9]        | #<br>2500                  | Maximum input frequency  |
| Press Δ [rPn]         | Rate unit                  |                          |
| Press Δ [Or]          | Overrun / non overrun mode |                          |
| Press Δ [FPF -y]      | Front panel reset          |                          |

# Automatically skips to value after 1 sec

**USER GUIDE**

**1. COUNTING DIRECTION**

**a. Unidirectional:** The unit counts the number of pulses received at the CNT1 input and can be programmed to count upwards from zero towards the set point (**Up counting**), or to count downwards from the set point to zero (**down counting**).

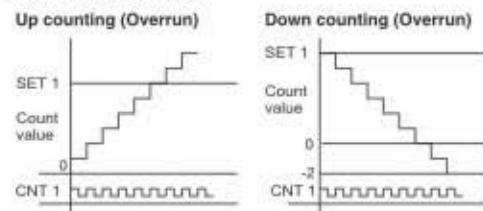

In Overrun mode, the unit continues to count above the set point.

**b. Bi-directional:**

In the Bi-directional mode of counting, the CNT2 input determines the count direction. If the CNT2 input is at level 1 (10V to 30V) XC200NX/XC1200 counts up (increments) - open terminals 3 & 4. If the CNT2 input is at level 0 (0V to 1V) the XC200NX/XC1200 counts down (decrements)-short terminals 3 & 4.

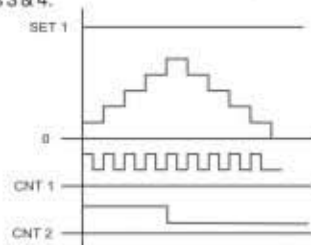

**c. Quadrature:** The Quadrature mode is suitable for using with sensors which generate 2 channels of output in quadrature (phase shift) e.g. Rotary encoders. The unit counts up (increments), if the CNT1 input transitions precede the CNT2 input transitions and counts down, if the CNT2 input transitions precede the CNT1 input transitions.

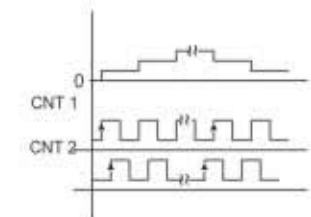

**2. MODES OF OPERATION**

**a) On delay:**

The output is energised at the end of the counting cycle (i.e. count value = set value) & remains on till unit is reset. When the number of pulses received is equal to SET2, relay 2 is switched ON, and when the number of pulses received equals Set1, relay 1 is switched ON. Both the outputs remain ON till the unit is reset.

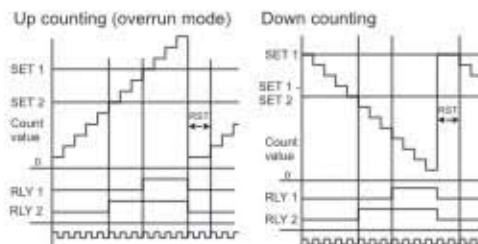

**b) Interval:**

The output is energised at the start of the counting cycle and de-energised on its completion. When the number of pulses received equal to SET2, relay2 is switched OFF, and when the number of pulses received equal to Set1, relay 1 is switched OFF. These relays remain OFF till the unit is reset.

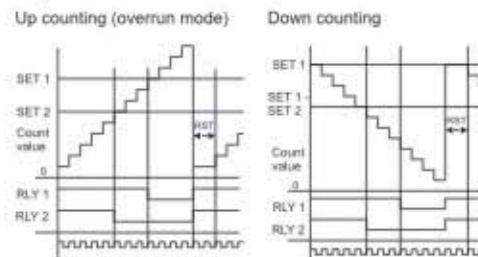

**c) Time Pulse Repeat (TPR):**

The output changes state (according to the On delay or Interval mode selected) for a programmed pulse time (t), at the end of the count cycle. After the set pulse time, the count resets automatically & count cycle repeats. Counting continues uninterrupted during the pulse time.

Time Pulse Repeat (Up Counting, On Delay)

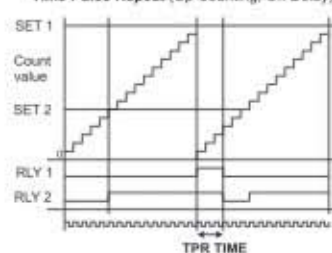

**d) Auto-reset mode:**

The output energises (according to the On delay or Interval delay mode selected) at the end of the count cycle for the programmed Auto reset time, after which the counter automatically resets and begins the next count cycle.

The unit remains reset for the Auto reset time and ignores count pulses received during this duration. It resumes operation only after this period has elapsed.

Auto Reset Mode (Up Counting, On Delay)

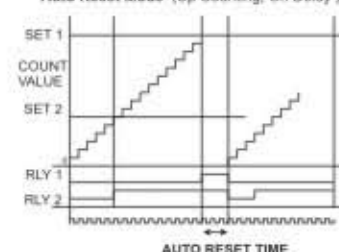

**Overrun / Non Overrun feature:**

**Overrun:** In overrun mode, the counter continues counting, after the SET1 value has been crossed.

**Non overrun:** In non overrun mode, the counter stops counting, after the SET1 value is reached and restarts counting only after reset.

**SCALE FACTOR**

The user programmable scale factor facilitates the direct reading in desired engineering unit.

The counter multiplies the number of pulses received at the count input with the scale factor, and displays the result.

**Count display = No. of pulses received x scale factor**  
**Rate display = Number of pulses received per minute x scale factor or No. of pulses received per hour x scale factor.**

The scale factor consists of two parts, mantissa and exponent.

The mantissa can be set from 0.00001 to 9.99999 and the exponent can be set from -5 to +2. The scale factor is arrived at as:

**Scale factor = Mantissa X 10<sup>\*\*\*\*\*</sup>**

**RATE DISPLAY**

The user can select either rate display or count display from the front panel keypad. The counter displays the rate with auto ranging facility. The relays will operate as in count mode, even if the rate display mode has been selected. The batch count and totaliser values will also be updated while display is in the rate mode.

(Specifications subject to change as development is a continuous process)

**Selec Controls Pvt. Ltd., India,**

(Formerly Selectron Process Controls Pvt. Ltd.)

Tel:91-22-28476443/1882, Fax:91-22-28471733,

Toll free: 1800 227 353, Website: www.selecindia.com

E- mail: sales@selecindia.com.

## 2. Press $\square$ key to select scale factor exponent

Factory setting: 0

|                       |                                    |  |
|-----------------------|------------------------------------|--|
| Scale factor exponent | $\overline{E P N} \overline{0}$ *  | Blinking digit<br>Exponent = 0 i.e. $10^0$ |
| Press $\Delta$        | $\overline{E P N} \overline{1}$ *  | Exponent = 1 i.e. $10^1$                   |
| Press $\Delta$        | $\overline{E P N} \overline{2}$ *  | Exponent = 2 i.e. $10^2$                   |
| Press $\Delta$        | $\overline{E P N} \overline{-5}$ * | Exponent = -5 i.e. $10^{-5}$               |
| Press $\Delta$        | $\overline{E P N} \overline{-4}$ * | Exponent = -4 i.e. $10^{-4}$               |
| Press $\Delta$        | $\overline{E P N} \overline{-3}$ * | Exponent = -3 i.e. $10^{-3}$               |
| Press $\Delta$        | $\overline{E P N} \overline{-2}$ * | Exponent = -2 i.e. $10^{-2}$               |
| Press $\Delta$        | $\overline{E P N} \overline{-1}$ * | Exponent = -1 i.e. $10^{-1}$               |

Note: Scale factor = Mantissa X  $10^{\text{Exponent}}$

## 3. Press $\square$ key to select Resolution

Factory setting: 1

| Display                                       | for 1 sec.           |
|---|----------------------|
| Press $\triangleright$ $\overline{000000}$ *  | Least count = 1      |
| Press $\triangleright$ $\overline{00.0000}$ * | Least count = 0.0001 |
| Press $\triangleright$ $\overline{000.000}$ * | Least count = 0.001  |
| Press $\triangleright$ $\overline{0000.00}$ * | Least count = 0.01   |
| Press $\triangleright$ $\overline{00000.0}$ * | Least count = 0.1    |

## 4. Press $\square$ key to select Counting mode

Factory setting: Bi-directional

|                |                          |                  |
|----------------|--------------------------|------------------|
| Counting mode  | $\overline{b i d i r}$ * | Bi - directional |
| Press $\Delta$ | $\overline{u p}$ *       | Up direction     |
| Press $\Delta$ | $\overline{d n}$ *       | Down direction   |
| Press $\Delta$ | $\overline{q u a d}$ *   | Quad direction   |

Note: Quadrature mode maximum speed - 2kHz  
(for higher speeds please contact factory).

## 5. Press $\square$ key to select Reset selection

Factory setting: zero  
Note: Applicable for Bi-directional and Quadrature modes only

|                 |                            |                 |
|-----------------|----------------------------|-----------------|
| Reset selection | $\overline{2 e r 0}$ *     | Reset to zero   |
| Press $\Delta$  | $\overline{p r e s e t}$ * | Reset to preset |

## 6. Press $\square$ key to select Relay operating mode

Factory setting: On delay

|                      |                      |               |
|----------------------|----------------------|---------------|
| Relay operating mode | $\overline{0 n}$ *   | On delay      |
| Press $\Delta$       | $\overline{i n t}$ * | Interval mode |

## 7. Press $\square$ key to select TPR/ AR mode

Factory setting: none

|                |                        |   |
|----------------|------------------------|---|
| TPR/ AR mode   | $\overline{n o n e}$ * | None (no Autoreset, no Time pulse repeat) |
| Press $\Delta$ | $\overline{a r}$ *     | Auto reset                                |
| Press $\Delta$ | $\overline{t p r}$ *   | Time pulse repeat                         |

## 8. Press $\square$ key to select Input frequency

Factory setting: 2500 Hz

| Display         | for 1 sec.             |        |
|-----------------|------------------------|--------|
| Input frequency | $\overline{3 0}$ *     | 30Hz   |
| Press $\Delta$  | $\overline{2 5 0 0}$ * | 2500Hz |
| Press $\Delta$  | $\overline{5 0 0 0}$ * | 5000Hz |

## 9. Press $\square$ key to select Rate unit

Factory setting: RPM

|                |                      |                      |
|----------------|----------------------|----------------------|
| Rate unit      | $\overline{r p m}$ * | RPM, Rate per minute |
| Press $\Delta$ | $\overline{r p h}$ * | RPH, Rate per hour   |

## 10. Press $\square$ key to select Overrun/non overrun

Factory setting: Over run

|                |                          |              |
|----------------|--------------------------|--------------|
| Overrun / NOR  | $\overline{0 r}$ *       | Overrun      |
| Press $\Delta$ | $\overline{n o n 0 r}$ * | Non- overrun |

## 11. Press $\square$ key to select Front panel reset

Factory setting: enabled

|                   |                          |                    |
|-------------------|--------------------------|--------------------|
| Front panel reset | $\overline{f p r - y}$ * | Reset key enabled  |
| Press $\Delta$    | $\overline{f p r - n}$ * | Reset key disabled |

## 12. Press $\square$ key to reset cumulative total and batch count

Factory setting: 0

|                |                          |  |
|----------------|--------------------------|--|
| Reset batch    | $\overline{r t o t 0}$ * | No action                              |
| Press $\Delta$ | $\overline{r t o t 1}$ * | No action                              |
| Press $\Delta$ | $\overline{r t o t 2}$ * | No action                              |
| Press $\Delta$ | $\overline{r t o t 3}$ * | No action                              |
| Press $\Delta$ | $\overline{r t o t 4}$ * | No action                              |
| Press $\Delta$ | $\overline{r t o t 5}$ * | Reset cumulative total and batch count |

## 13. Press $\square$ key to select Reset all (initialisation)

Note: At reset all, all parameters reset to factory settings.

|                |                        |  |
|----------------|------------------------|--|
| Reset all      | $\overline{r s t 0}$ * | No reset   |
| Press $\Delta$ | $\overline{r s t 1}$ * | No reset   |
| Press $\Delta$ | $\overline{r s t 2}$ * | No reset   |
| Press $\Delta$ | $\overline{r s t 3}$ * | No reset   |
| Press $\Delta$ | $\overline{r s t 4}$ * | No reset   |
| Press $\Delta$ | $\overline{r s t 5}$ * | Reset all (all parameters reset to factory settings) |

NOTE: Value of parameter is stored after pressing  $\square$  key. To quit configuration mode:

- 1) Turn power off
- 2) Remove link between CONFIG terminal nos. 13 & 14 (XC200NX) or terminals 9 & 10 (XC1200)
- 3) Turn power on

To program SET 1, SET 2 & AR / TPR time:  
In programming mode the digit which is blinking can be changed. The blinking digit increments by 1 for every press of  $\Delta$  key & rolls over from 9 to 0. The blinking shifts to next digit (right) for every press of  $\triangleright$  key. Using these keys you can set the required value.

| KEY PRESS  | DISPLAY                    | DESCRIPTION                  |
|--|----------------------------|------------------------------|
| Press $\triangleright$ for 3 sec.                    | $\overline{S E t 1}$ #     | Set value 1                  |
| (Factory setting: 100)                               | $\overline{0 0 0 1 0 0}$ * | Set as per procedure given.  |
| Press $\square$                                      | $\overline{S E t 2}$ #     | Set value 2                  |
| (Factory setting: 90)                                | $\overline{0 0 0 0 9 0}$ * | Set as per procedure given.  |
| Press $\square$                                      | $\overline{t i n e}$ #     | Pulse time                   |
|  | $\overline{0 0 . 0}$ *     | Maximum pulse time = 99.9sec |
| Press $\square$ key to complete programming          |                            |                              |
| Note:  |                            |                              |
| a) Time parameter is valid for AR and TPR modes only |                            |                              |
| b) SET1 should always be greater than SET2           |                            |                              |

## Selecting the Count or Rate display:

The unit displays toggles between rate and count mode at the momentary press of  $\square$  key.

|                          |                          |                     |
|--------------------------|--------------------------|---------------------|
| Press $\square$          | $\overline{t o t a l}$ # | Current Count value |
| (Factory setting: Total) | $\overline{0 0 0 0 0 0}$ |                     |
| Press $\square$          | $\overline{r a t e}$ #   | Rate value          |
|                          | $\overline{0 0 0 . 0 0}$ |                     |

## TO READ SET 1, SET 2 & PULSE TIME VALUES

| KEY PRESS                          | DISPLAY                  | NAME        |
|------------------------------------|--------------------------|-------------|
| Press $\triangleright$ (momentary) | $\overline{S E t 1}$ #   | Set 1 value |
|                                    | $\overline{0 0 0 0 0 0}$ |             |
| Press $\triangleright$ (momentary) | $\overline{S E t 2}$ #   | Set 2 value |
|                                    | $\overline{0 0 0 0 0 0}$ |             |
| Press $\triangleright$ (momentary) | $\overline{t i n e}$ #   | Time        |
|                                    | $\overline{0 0 . 0}$     |             |

This step is valid only for AR / TPR selection.