

DUAL SET POINT PROGRAMMABLE TIMER

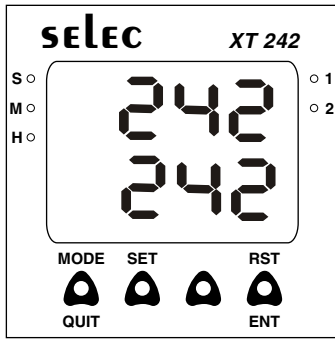

OPERATING MODES :

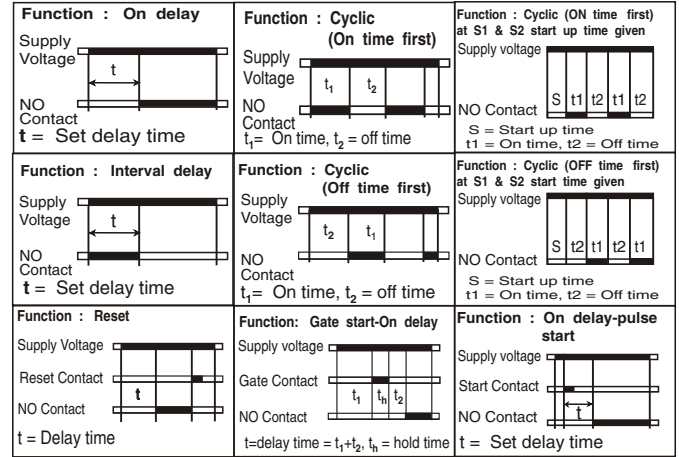

SPECIFICATIONS :

- DISPLAY** Current value: 4 digit red.
Set value: 4 digit green, both 0.5" height.
- SET POINTS** 2.
- TIME RANGES** 99.99 / 999.9 / 9999 sec, 99:59 min:sec,
999.9 / 9999 min, 999.9 / 9999 hr.
- COUNTING DIRECTION** Up / Down.
- BATCH COUNTS MODES** Up to 9999.
a) ON delay b) Interval c) Cyclic ON first
d)Cyclic OFF first.
- TIME SETTING MEMORY** By front keypad.
10 years.
- LED INDICATION** a) Relay status b) Time unit (sec / min / hr)
Note: When timing is in progress unit LED
blinks to indicate timing on & unit of range.
When timing is in hold mode, blinking stops.
2 C/O (DPDT).
- OUTPUTS** 5A @ 230 V AC/ 28 V DC resistive load.
- RELAY RATING** a) Start b) Reset
via rear terminals.
- INPUTS** a) Front panel.
b) Rear terminal.
c) ON power interruption (programmable).
- CONFIGURATION LOCK** Less than 100 msec.
- RESET** ± 0.05% or 50 msec whichever is greater.
- RESET TIME** 90 to 270V AC/DC @ 50/60Hz.
- ACCURACY** Panel mounting.
- SUPPLY** ABS.
- MOUNTING** 375 gms. (approx).
- HOUSING** Operating: 0 to 50°C.
- WEIGHT** Storage: -5 to 55° C.
- TEMPERATURE** 95% RH.
- HUMIDITY**

TERMINAL CONNECTIONS

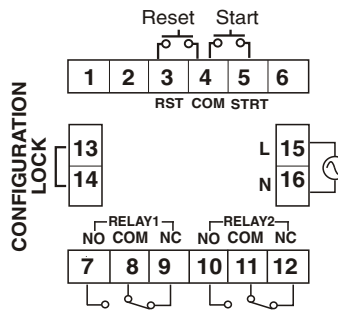

TERMINAL	DESCRIPTION
3	RESET
4	COM for Start / Reset
5	START
7	NO of relay 1
8	COM of relay 1
9	NC of relay 1
10	NO of relay 2
11	COM of relay 2
12	NC of relay 2
13 & 14	Configuration lock
15	LIVE (SUPPLY)
16	NEUTRAL (SUPPLY)

TYPICAL CONNECTIONS FOR LOADS :

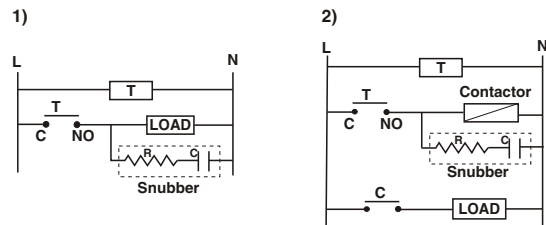

NOTE: Use snubber across inductive load to increase life of the internal relay of the timer.

ELECTRICAL PRECAUTIONS DURING USE

High voltage spikes are generated in industrial electrical systems due to the switching / operation of inductive loads, termed as 'Noise'. Noise can create momentary disruption, erratic display, latch up, data loss or permanent damage to the instrument. To reduce noise:
a) Use of MOV across supply of timer & snubber circuits across loads are recommended
b) Use separate shielded wires for inputs.

RESETTING THE XT242

A) By front key : (programmable)

1. By pressing ENT key continuously for 3 sec.
2. By pressing ENT key momentary

B) Remote reset : The XT242 can be reset from a remote push button as shown in the figure.

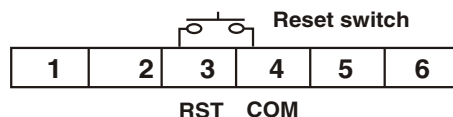

DIMENSIONS (in mm) :

Bezel size : 72mm(H) x 72mm(W)
Panel cutout : 69mm(H) x 69mm(W)
Depth behind panel : 115mm

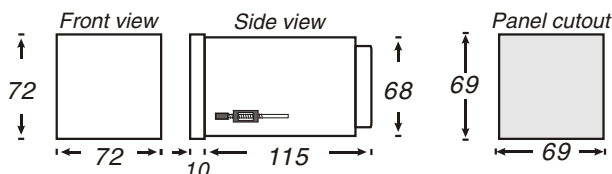

(Specifications subject to change as development is a continuous process)

CONFIGURATION MODE: Short terminal nos. 13 & 14

NOTE:

- 1) To enter or exit configuration mode, press MODE key for 3 Sec.
- 2) To go to next parameter programming, press ENT key for 3 Sec.
- 3) In programming mode the lower display blinks continuously.

KEY PRESS FOR 3 Sec	UPPER DISPLAY	LOWER DISPLAY	DESCRIPTION/ COMMENTS (To select parameter press MODE key momentarily)
MODE Key	MODE	MODE	Select: a) MODE for all functions. b) MODE for limited functions.
ENT Key	99.99	99.99	Time ranges selectable as a) 99.99 Sec. b) 999.9 Sec. c) 9999 Sec. d) 99.59 min : sec. e) 999.9 min f) 9999 min g) 999.9 hr. h) 9999 hr.
ENT Key	00	00	Select delay type as (a) 00 (On delay) (b) 00 (Interval) (c) 00 (Cyclic with ON time first) (d) 00 (Cyclic with OFF time first)
ENT Key	YES	YES	Select Power On Reset as a) YES b) NO . If YES : timer resets on power interruption. If NO : timer functions as a battery backup timer.
ENT Key	00	00	If MODE mode is selected then PSE will appear at the end. Select reset as (a) YES b) NO YES All parameters set to default. They are Set 1 Start time, on time, off time = 0 Set 2 Start time, on time, off time = 0, Batch total = 0, No. of Pulses = 0, Mode = complex, Range = 99.99 Sec, Delay mode = ON delay, POR = No, Direction = Down, Front panel reset = Yes, Start input = Gate. NO Timer will function as per previous setting.

NOTE: The below parameters will not appear in MODE mode. In simple mode these are factory sets as follows: a) Count direction: down, b) Front panel reset: yes, c) Start input: gate & d) No of cycle pulses: 0 (continuous).

ENT Key	DOWN	DOWN	Select count direction as (a) UP (b) DOWN
ENT Key	YES	YES	Select Front Panel Reset as (a) YES (b) NO YES Reset by front key enable NO Reset by front key disable
ENT Key	GATE	GATE	Select start input= (a) GATE (b) PUL GATE When start (Gate) is high (contact closed) the relay state does not change but the time counting stops (hold). On release of contact, time counting starts from the last time count. PUL Timing starts on application of external signal (open to close)
ENT Key	0000	0000	Select PUL : This will appear if cyclic mode is selected in operating mode. Set no. of cyclic operations for relay one by using ▲ keys momentarily. If 0000 is selected then timer will operate continuously in cyclic mode.
ENT Key	00	00	The function of this parameters is same as explained earlier.

NOTE: After selecting PSE press ENT key for 3 Sec. The timer will come out from configuration programming and will start functioning as per the configuration settings. Remove link between terminal nos. 13 & 14.

SET VALUES PROGRAMMING:

To enter set value programming: Press SET key continuously for 3 sec.

To change value (timing) : For 4 digits, four ▲ keys are provided. The digit above ▲ key increments by one for each momentary press of ▲ key. The appropriate value can be selected accordingly by using ▲ keys. After selecting appropriate time value press ENT key continuously for 3 sec to go to next step of programming.

To exit set value programming: Press MODE key continuously for 3 sec.

NOTE:

1. Set 2 has to be always less than Set 1 in ON & OFF delay mode. If set 2 value is greater than Set 1, the Set 2 relay does not operate.
2. In down counting mode, relay 2 operates when time elapsed = set 2.

Set point Programming for ON/ OFF Delay mode			
KEY PRESS FOR 3 Sec.	UPPER DISPLAY	LOWER DISPLAY	COMMENTS
SET Key	1-dL	0000	Set 1 delay time
ENT Key	2-dL	0000	Set 2 delay time
Set point programming for CYCLIC mode			
SET Key	1-St	0000	Set 1 startup time
ENT Key	1-On	0000	Set 1 on time
ENT Key	1-Of	0000	Set 1 off time
ENT Key	2-St	0000	Set 2 startup time
ENT Key	2-On	0000	Set 2 on time
ENT Key	2-Of	0000	Set 2 off time

NOTE:

- 1) After selecting 2-dL in ON/ OFF delay mode & 2-Of in CYCLIC mode press ENT key for 3sec. The timer will come out of programming & will start functioning as per the settings.
- 2) If start up time = 0000 then no start up delay (It is applicable for cyclic ON first & cyclic OFF first modes.)

Press Third Key from left momentarily i.e. key next to SET key	BATCH	0000	Batch total is incremented by one after each one cycle completed.
Press ENT Key for 3 Sec	BATCH	NO	BATCH is selected as YES or NO by momentarily pressing MODE key. If ENT key is pressed for 3 Sec. at YES batch total is reset. At NO Batch total will not reset.

NOTE: On continuous press of 'MODE KEY' after selecting 'YES' or 'NO', it quits batch reset without altering batch total.

READ MODE:

To read Set 1 / set 2 delay time in ON delay or Interval mode

KEY PRESS (momentary)	UPPER DISPLAY	LOWER DISPLAY	DESCRIPTION / COMMENTS
SET key	1-dL	0000	lower display shows delay time of set 1
SET key	2-dL	0000	lower display shows delay time of set 2
To read Startup time & Set 1 / Set 2 ON/ OFF time in CYCLIC mode			
SET key	1-St	0000	lower display shows set 1 startup time
SET key	1-On	0000	lower display shows set 1 on time
SET key	1-Of	0000	lower display shows set 1 off time
SET key	2-St	0000	lower display shows set 2 startup time
SET key	2-On	0000	lower display shows set 2 on time
SET key	2-Of	0000	lower display shows set 2 off time